

POLYSTAINLESS

COMPOSITE FENCING SPIGOT

NEW!

POLYSTAINLESS POOL FENCING SPIGOT

- NON-CONDUCTIVE
- NO EARTHING REQUIRED
- SAVE TIME & MONEY

The polystainless fencing spigot is made from extremely durable non-conductive composite material (patented product). Being non-conductive means there is no requirement for earthing under AS3000:2007 (equipotential bonding).

Years of research and development has led to the formulation of a new composite material giving a stainless steel feel and appearance. Other composites have a 'plastic' look and feel while also lacking in strength.

Polystainless is a genuine industry first product innovation which overcomes requirement of earthing spigots for pool fencing.

**Patented
product!**

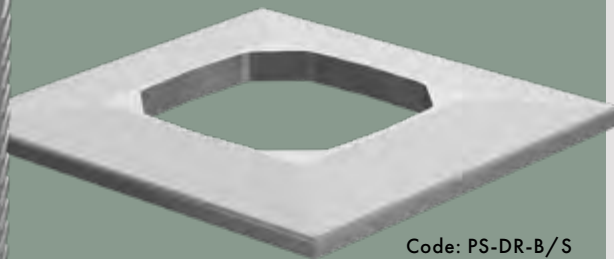

Code: PS-S-B/S

Code: PS-DR-B/S

SPECIFICATIONS —

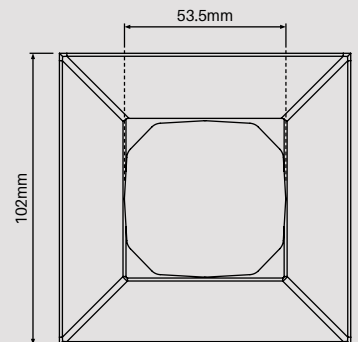
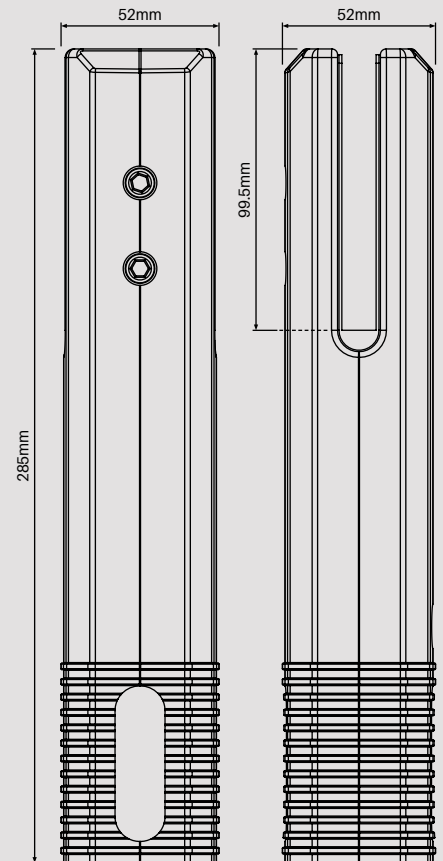

- No electrician required for earthing - save time and money!
- NATA tested in accordance with Australian Standards (AS1926.1 Safety Barriers for Pools)
- Made from ultra-robust, UV stabilised reinforced composite material giving a stainless steel feel and appearance (patented product)
- Composite construction – surface will not rust or corrode
- Suits 12mm thick glass panels
- Designed for core drill installations
- Recessed friction plate for ease of install
- Spigot and dress ring available in matt black or silver finish

NO EARTHING REQUIRED

SAVE TIME & MONEY

STYLISH SPIGOT DESIGN